

General Description

The Protocol dimming and control systems offer microprocessor based control stations, load drivers, input and output interface modules, with **distributed intelligence** (no central controller) over the 4-wire (2 twisted pairs) network bus, increasing the reliability and versatility of the system. The **DCI-16** is a **dry contact input interface module that can be used to link other systems, such as A/V, alarm, and time clocks to the Protocol system.** The **DCI-16** may be viewed as a control station with 16 "phantom" button inputs. **A relay closure from an external device connected to the DCI-16 is interpreted in the same way as a button press on a control station.** Switch input functions and control channel assignment are programmed and loaded into the **DCI-16**, as if it were a control station, by means of Protocol programming software. These can be assigned at the factory and easily reprogrammed in the field whenever necessary to accommodate the changing needs of the application. Normally, the inputs of the **DCI-16** are programmed as "Preset" functions. An external system is then **able to recall up to 16 system presets** by momentarily closing and releasing relays connected to the inputs. Relay closures must be maintained for a period of (0.5 +/- 20%) second.

The DCI-16 comes in an open-frame circuit module that can be integrated into existing system cabinets. It is also available installed inside a 12" x 8" x 4" NEMA enclosure.

Switch Input Functions

- Dimmer w/preset On and Off
- Raise
- Lower
- On
- Off
- Toggle
- Momentary
- Preset

Input Load Assignment

- Single load.
 - Group of loads (up to 24)
 - All Loads (global)
 - All loads excluding a group.
- Above load assignment options are available with any input function.

Fade Rate Assignment

- Level Control (0 to 25 seconds)
- Preset Fade (0 to 60 minutes)

Software Diagnostics

- Auto Detect Station (**DCI-16**).
- Send ID and Code Version.
- Check Station (**DCI-16**).
- Send Factory Settings.
- Modify Settings.
- Default To Factory Settings.
- Save Current Settings.
- Soft Reset.
- Initialize Memory.
- Monitor Input Closures.
- Send Input Configuration.
- Swap Inputs.
- Lock/unlock "Preset Save".
- Flash **DCI-16** LED's.
- Download Configuration File.

Note

The "Preset Save" function may be disabled, after saving the modules presets, by locking the Presets for the entire module, using the RAU.

Physical and Electrical Specifications

Design: Open-frame circuit module.
 Dimensions: See Drawing On Page 1.
 Power: Max. 80 mA at 10 VAC-50/60 Hz.
 Data Input/Output: RS485 Compliant.
 Data Format: Proprietary.
 Data Retention: 10 years, no batteries required.
 ESD Protection: 15 KV on data input and output.
 Network Port: 4-Position screw terminal.
 Contact Input Port: 2 x 16-Position screw terminals.

Switch Contact Timing Specifications

Dim-On/OFF, Toggle, On, OFF and Preset Recall:

- 1 Close Relay Contact.
- 2 Maintain Contact Closure for (0.5+/- 20% Second).
- 3 Release Relay Contact.

Dimmer Ramp, Raise and Lower:

Close Relay Contact, Release at Desired Level.

Preset Save:

Close Relay Contact, Release after (6 +/- 20%) Seconds.

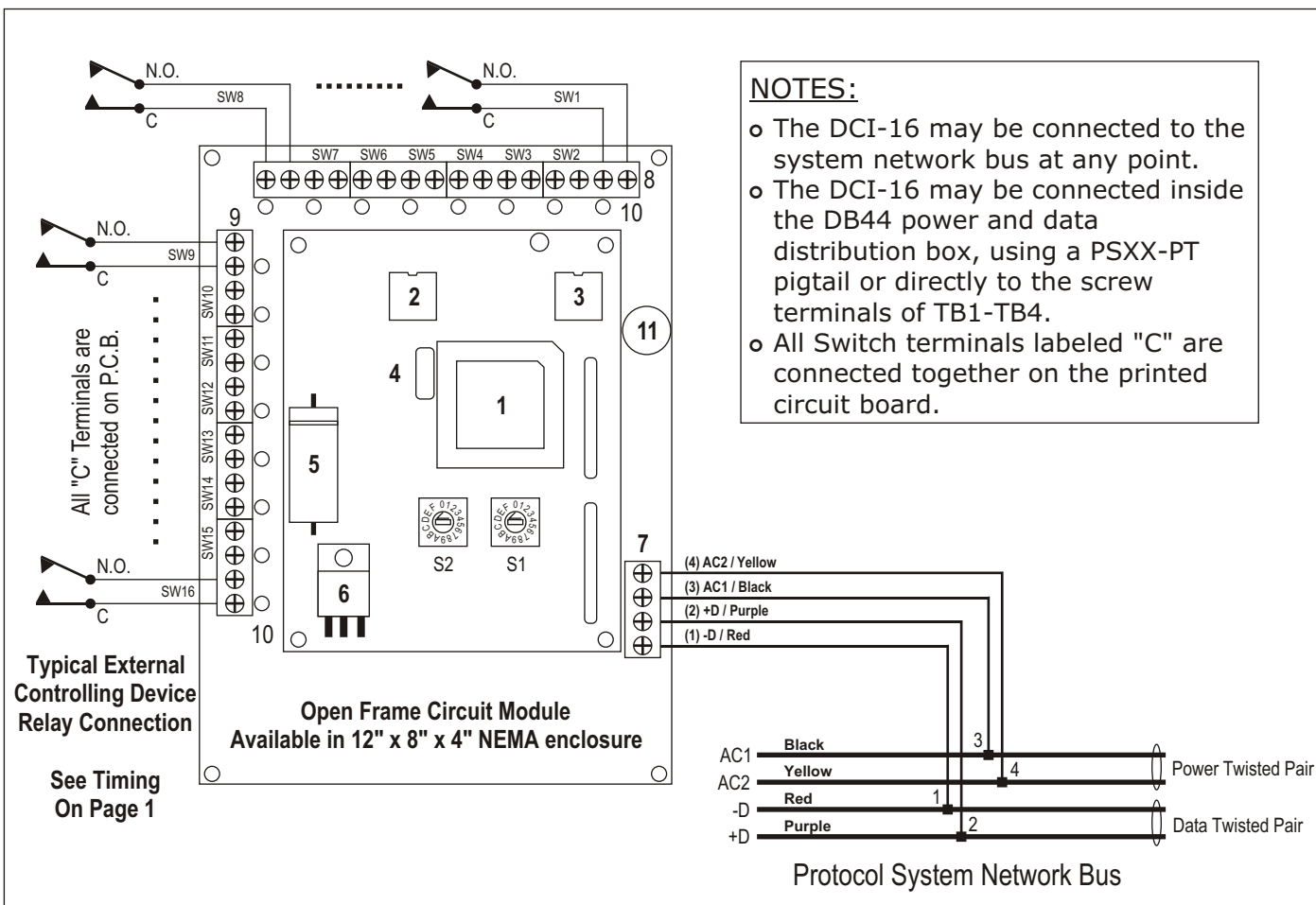

Mounting requirements

- The **DCI-16** open-frame circuit module may be installed inside existing enclosures using metal spacers and mounting hardware.
- The **DCI-16NE** comes inside an 8" x 12" x 4" NEMA enclosure.
- Use Grounded metal enclosures only.
- Refer to the Protocol Hardware Installation Manual or consult factory for more details.

Ordering Information

- o **DCI-16:** Open-frame circuit module.
- o **DCI-16NE:** DCI-16 module installed inside a 12" x 8" x 4" NEMA enclosure.

Wiring Notes

- 1 All wiring between the control stations, load drivers, and other system accessories (network bus) is low voltage (NEMA Class 2) and may be run with two twisted pair # 18 AWG wire. Refer to Protocol Installation Manual, Appendix E, for maximum wire length. Network Bus may be Carol Cable #C3362 unless otherwise required.
- 2 Do not run Network Bus cable in the same conduit with non-class 2 circuits.
- 3 Network Bus wire may be run in any combination of daisy chain (T-tap), home run, star, and/or branch.
- 4 Power for all stations of a system must be on the same power phase.

