



Digital Lighting Systems, Inc.

PD404

Four Channel Dimmer and Switch Packs

PROTOCOL

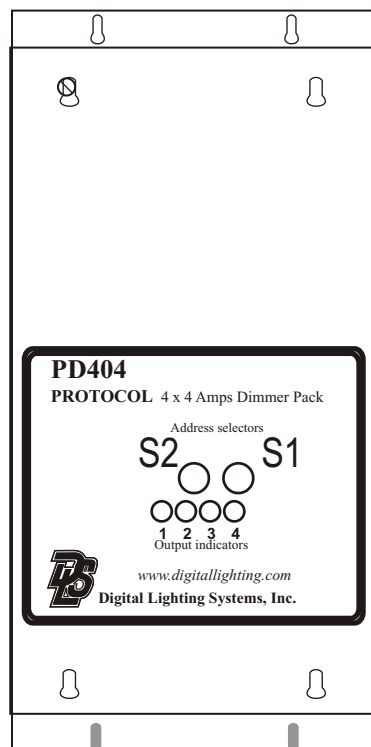

USER'S MANUAL

GENERAL DESCRIPTION

The **PD404** is a 4-channel dimmer pack for the **PROTOCOL** lighting control system. The **PD404** dimmer pack contains 4 solid-state dimmers. Power is fed to the **PD404** from One 20 Amp. breaker. Each dimmer is rated for a maximum output current of 4 amperes (**480 Watts at 120 VAC**). The **PD404** contains two printed circuit boards, the load driver module (**LDM**) and an **INT04** control modules. The dimmers are triggered by the firing board (**INT04**).

THE INT04 - (See diagram on Page 2)

The **INT04** is a microprocessor based control board with a nonvolatile memory chip, a communications chip, and a regulated DC power supply. The **INT04** also contains, address selectors, LED output monitors and other support circuitry. The microprocessor is driven by powerful distributed intelligence software which handles all control and communications functions. The memory chip on the **INT04** holds all of the **PD404**'s pertinent information and settings which include low and high trim levels for each of the four outputs it controls.

The **PD404** **does not rely on any shared data source and functions independently** of any other system component and without a central system controller. The **PD404** communicates with Protocol system stations and controllers over a **single twisted-pair of wires** and **can be connected anywhere on the system network bus**. This adds convenience and versatility by allowing **PD404** dimmers to be installed close to their loads and/or service panels.

THE LDM (LOAD DRIVER MODULE) - (See Diagram on Page 2)

The LDM is equivalent to four solid-state relays (SSR's) assembled on a single circuit board. The **LDM** is mounted at the bottom of the **PD404**'s enclosure which also serves as a heat sink. The relays are triggered by low-voltage signals generated by the **INT04** module. These signals are optically-isolated by the **LDM** circuitry from all line voltage elements. A step-down 9 VAC- transformer on the LDM board supplies power to the **INT04** module described above.

OTHER INFORMATION- (See diagram Page 4)

Several **PD DIMMERS (PD404, PD804, PD408 and PD216** dimmer packs) may be daisy-chained together in any combination, up to a maximum of 63 individually addressed **INT04**'s (each **PD404, PD408** and **PD216** has 1x **INT04** each, each **PD804** has two **INT04**'s). **PD Dimmers** are daisy-chained using the **RJPD-6** cables (cat5 network cables) supplied with the units. Each **PD404** has a set of address selectors which must be set to a unique address. Please see **Table 4** on **Page 9** of this manual or the **PROTOCOL SOFTWARE MANUAL** for more information on addressing the **PD404** dimmer pack.

DIMMING/SWITCHING - (See Page 8 for more information)

Through the **PROTOCOL**'s "**SOFTPRO**" configuration software, each of the **PD404** outputs may be independently configured not to dim. **PD404** may control any combination of dimmed and switched loads.

There is also a **HARDWARE** lock to ensure circuits do not dim. All four outputs controlled by the **INT04** may be configured not to dim by the installation of a small jumper on the back of the **INT04** circuit board. This may be done at the factory or in the field. This jumper may be removed to allow the future dimming of those outputs. Please see **Page 8** for location of this jumper.

Alternatively, the **PD404** may be ordered as a **SWITCH-ONLY** unit, the **PD404-S**. This unit has all the same features as the **PD404** except that there is no dimming, and there are no chokes installed inside the unit. All other information in this manual

PD404 Load Driver Module Information

Figure 1 - PD404 LDM Detail

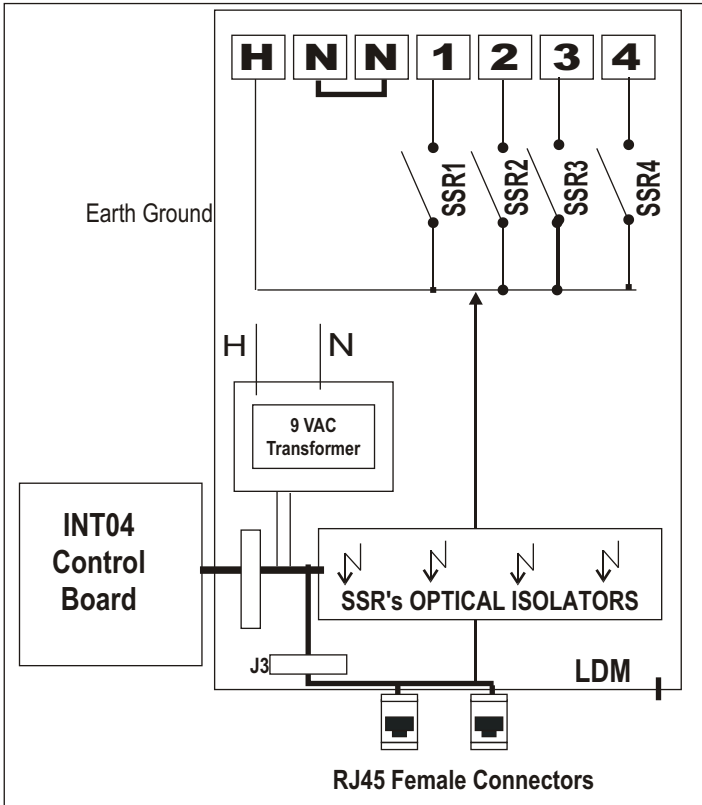

Table 1 - Terminals Definition

NAME	DESCRIPTION
1	Output Of Solid-State Relay #1
2	Output Of Solid-State Relay #2
3	Output Of Solid-State Relay #3
4	Output Of Solid-State Relay #4
H	Hot Line Feed For Relays 1 , 2 , 3 & 4.
N	Neutral Bus Connections.

Table 2 - Absolute Maximum Electrical Ratings

Electrical Characteristic Terminal Maximum

Relay Load Current	1 to 4	4 Amps.
Input Current	H	20 Amps.
Input Voltage	H	120 VAC

PD404- INT04 Detail

Table 3 - INT04 Circuit Legend

1	Microprocessor.
2	Nonvolatile Memory.
3	Communications Chip.
4	Quartz Crystal.
5	Power Supply Capacitor.
6	Voltage Regulator.
7	Signal & Power Connector.
8	Output LED Monitors.
9	Jumper for switches only

S1-S2 Address Selectors.

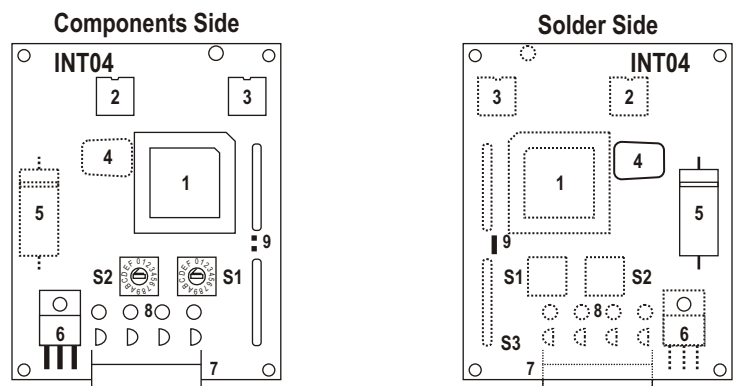

Figure 2 - PD404 / INT04 PROTOCOL Firing board Detail

NOTE:
PD404 has one INT04 control board.

Enclosure Installation

Surface mount the dimmer pack in a well ventilated area where the ambient temperature does not exceed 104° F for full load operation. Allow 2" of side clearance for proper air circulation and servicing. Installation clearance shall meet local and/or NEC code requirements. Enclosures may be attached to the wall or other mounting surface by holes in the heat sink flanges. Refer to the drawings below (FIGURE 3) for the correct dimensions. Conduit shall be pulled to the top of the dimmer packs.

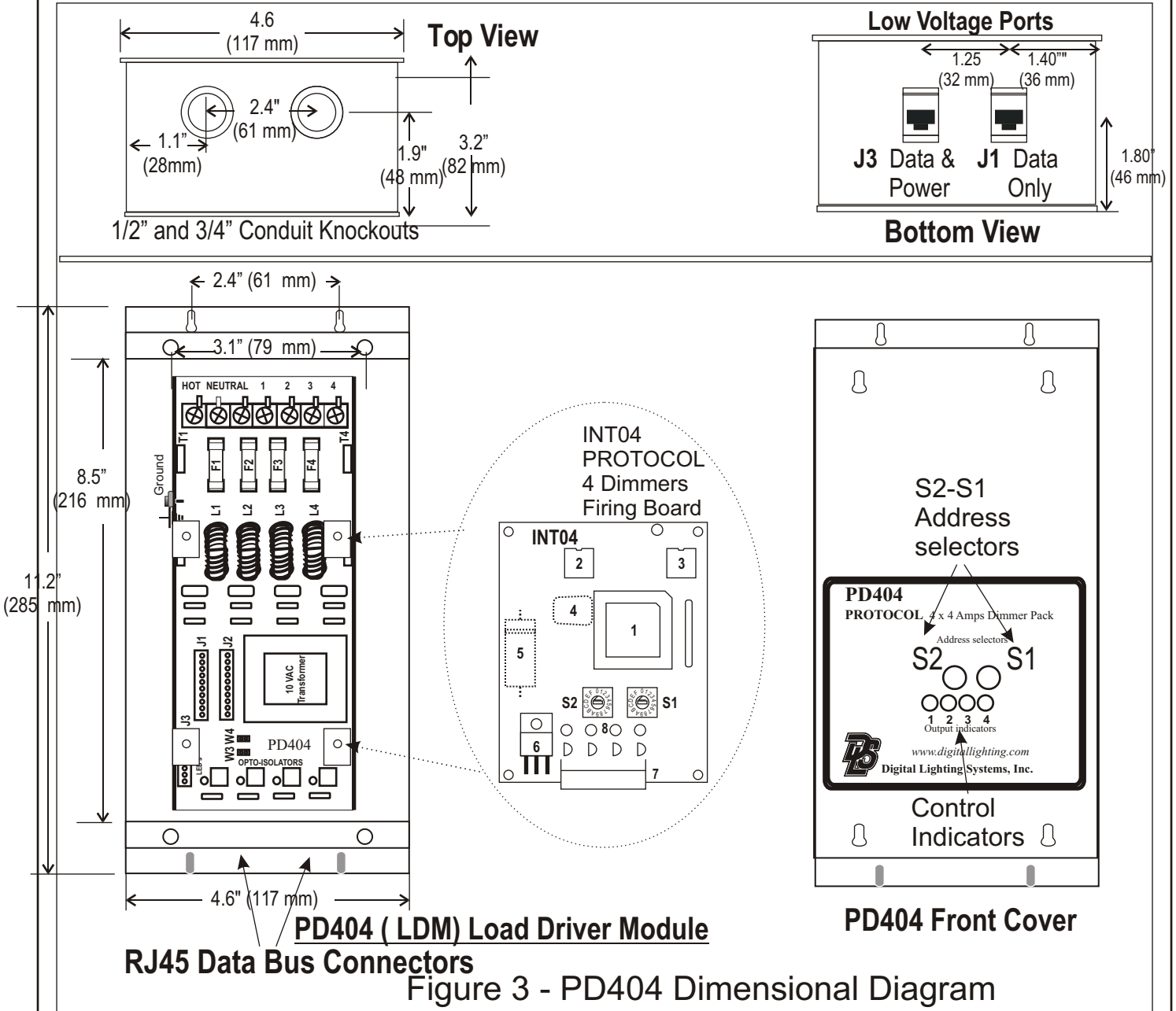

Figure 3 - PD404 Dimensional Diagram

PD404 Low Voltage Wiring Methods

W1-W2 Shunt Jumpers

Protocol systems with 3 control nodes or less (**PS Series** stations, **DCO**, **DCI** or **RAU**) do not require an external power supply transformer. Power for these components can be supplied by one of the **PD DIMMER** packs. *Figure 4* shows the **PD404's** network ports with its pin assignments. Installing W1 and W2 connects the 9 VAC transformer output to the network bus via J3. The 9 VAC output is permanently connected to J1. *Figure 5* shows a typical small system with one **PD Dimmer** supplying power to the network. *Figure 6* shows a typical system with an external transformer. System accessories such as extension cables and jumper boards are available from DLS and can simplify network bus connections.

TO AVOID PARALLELING THE OUTPUTS OF SEVERAL TRANSFORMERS IN A PROTOCOL SYSTEM:

- ⊗ Do not install the jumpers in any of the PD Dimmers when a DB44 panel with an external transformer is used in a system.
- ⊗ Do not install jumpers in more than one PD Dimmer per system when no external transformer is used.

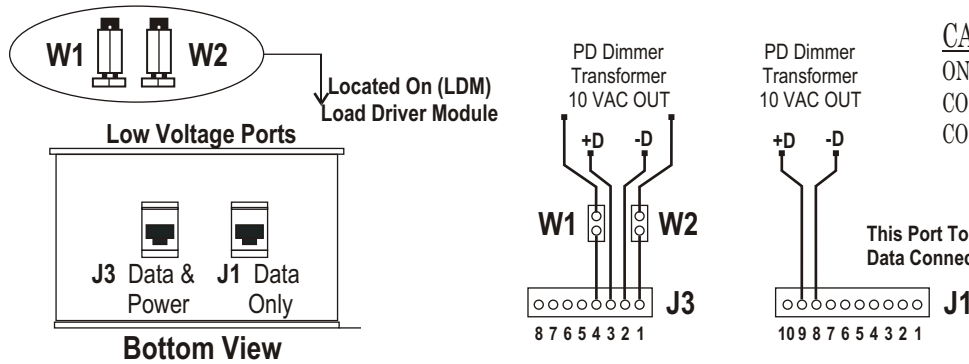

CAUTION
ONLY ONE SET OF W1-W2 JUMPERS PER SYSTEM!
CONNECT ONLY TO J1 PINS 8 & 9.
CONNECT ONLY TO J3 PINS 1-4.

Figure 4
PD Dimmer Network Ports Internal Connections.

Figure 5 -
Typical System Powered By a PD Dimmer Module

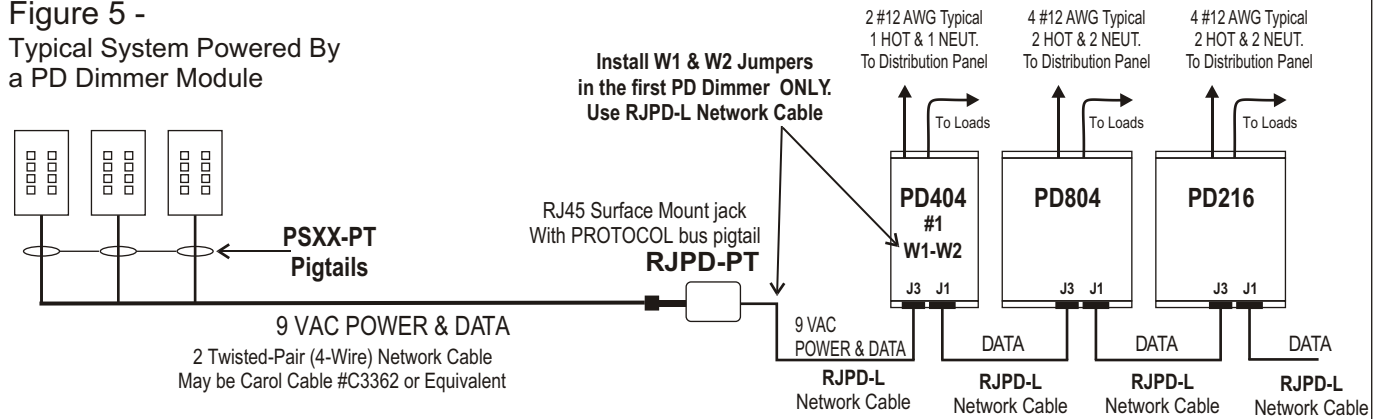
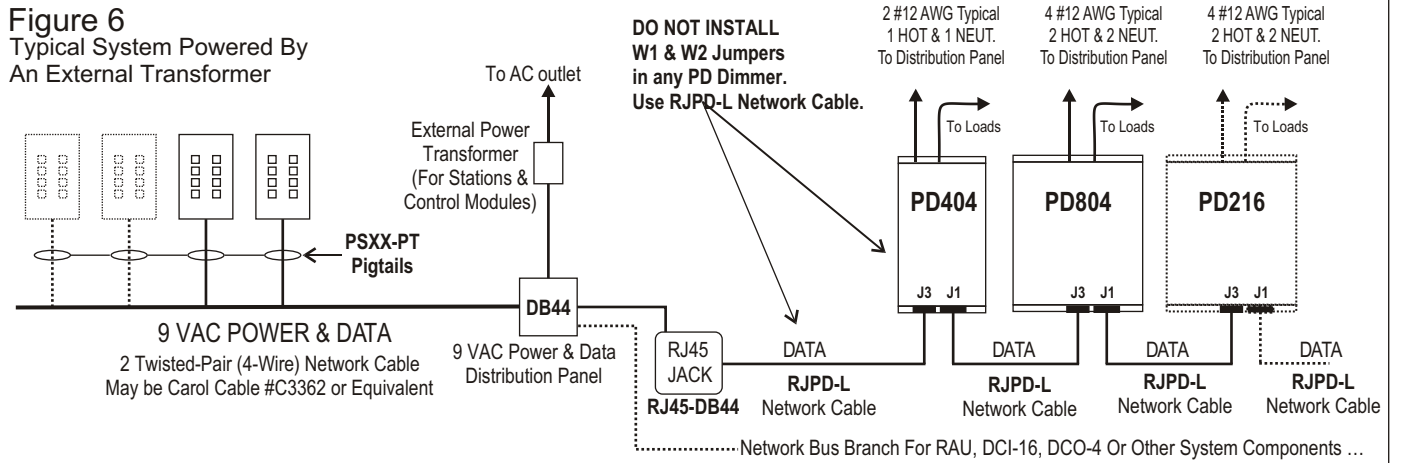

Figure 6
Typical System Powered By An External Transformer



PD404-120VAC General Wiring Instructions

Wiring Notes

- ❑ DO NOT EXCEED 480 W (4 Amps.) per dimmer output @ 120VAC.
- ❑ All wiring between the control stations, dimmers, and other system controllers (network bus) is low voltage (NEMA Class 2) and may be run with two, twisted pair, shielded #18 AWG wire. Control network bus may be Carol Cable #C3362 unless otherwise required. Consult the PROTOCOL Hardware Installation Manual, Appendix E, for maximum wire length.
- ❑ PD404 dimmer packs may be fed by one 20 A (maximum) branch circuits and may have up to four separately dimmed loads.
- ❑ CAUTION: DO NOT attempt to parallel outputs to increase capacity.
- ❑ Installation must conform to local and/or NEC code requirements and must be performed by a qualified electrician.
- ❑ All line voltage wires must have copper conductors of adequate Gauge with 90 C wire insulation.
- ❑ POWER EACH LOAD DIRECTLY BEFORE CONNECTING IT TO THE PD404 TO ENSURE PROPER WIRING.

Figure 7 - PD404 Typical 120 VAC Wiring.

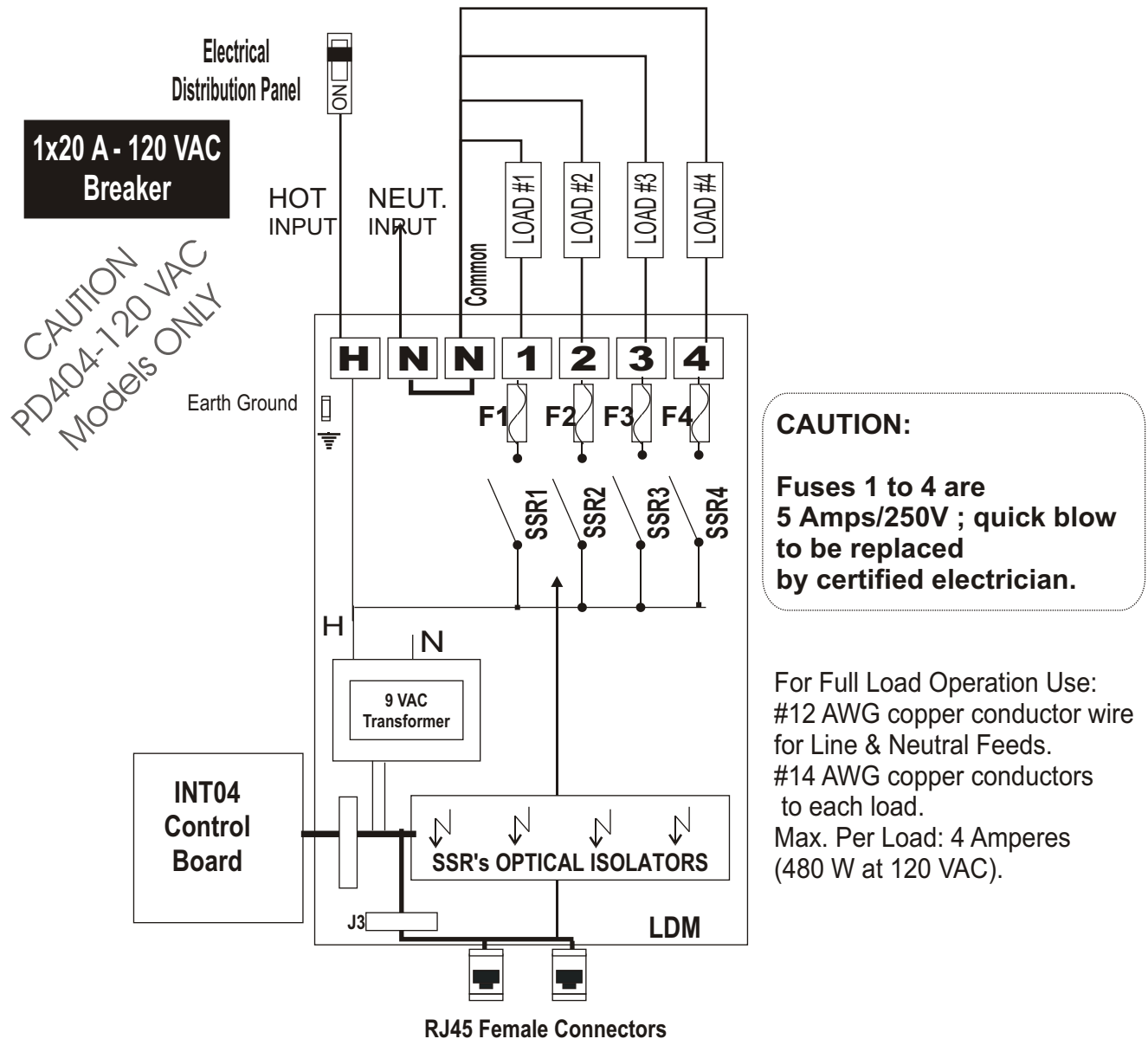

PD404-220VAC General Wiring Instructions

Wiring Notes

- ❑ DO NOT EXCEED 960 W (4 Amps.) per dimmer output @ 240 VAC.
- ❑ All wiring between the control stations, dimmers, and other system controllers (network bus) is low voltage (NEMA Class 2) and may be run with two, twisted pair, shielded #18 AWG wire. Control network bus may be Carol Cable #C3362 unless otherwise required. Consult the PROTOCOL Hardware Installation Manual, Appendix E, for maximum wire length.
- ❑ PD404 dimmer packs may be fed by one 20 A (maximum) branch circuits and may have up to four separately dimmed loads.
- ❑ CAUTION: DO NOT attempt to parallel outputs to increase capacity.
- ❑ Installation must conform to local and/or NEC code requirements and must be performed by a qualified electrician.
- ❑ All line voltage wires must have copper conductors of adequate Gauge with 90 C wire insulation.
- ❑ POWER EACH LOAD DIRECTLY BEFORE CONNECTING IT TO THE PD404 TO ENSURE PROPER WIRING.

Figure 8 - PD404 Typical 220/240 VAC Wiring.

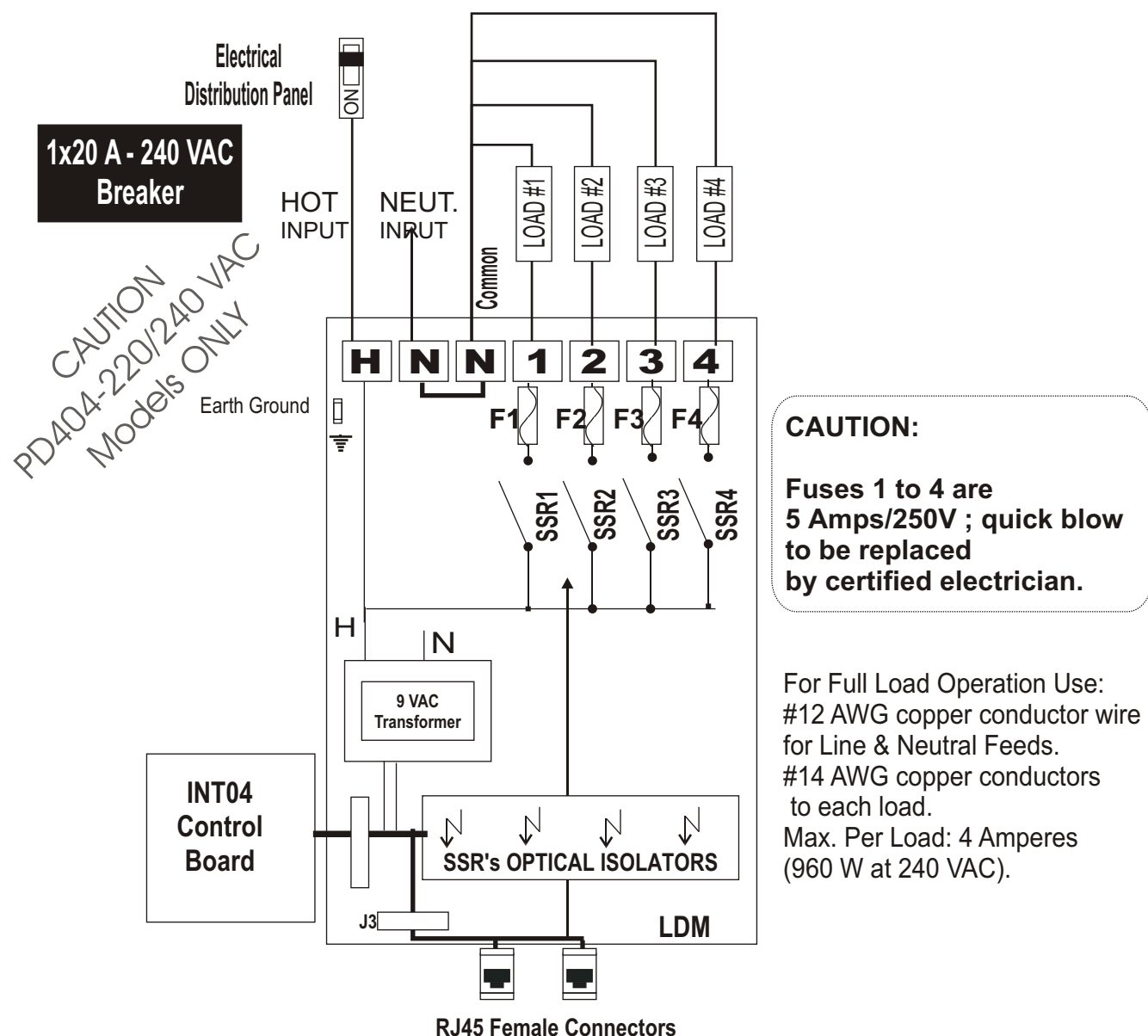
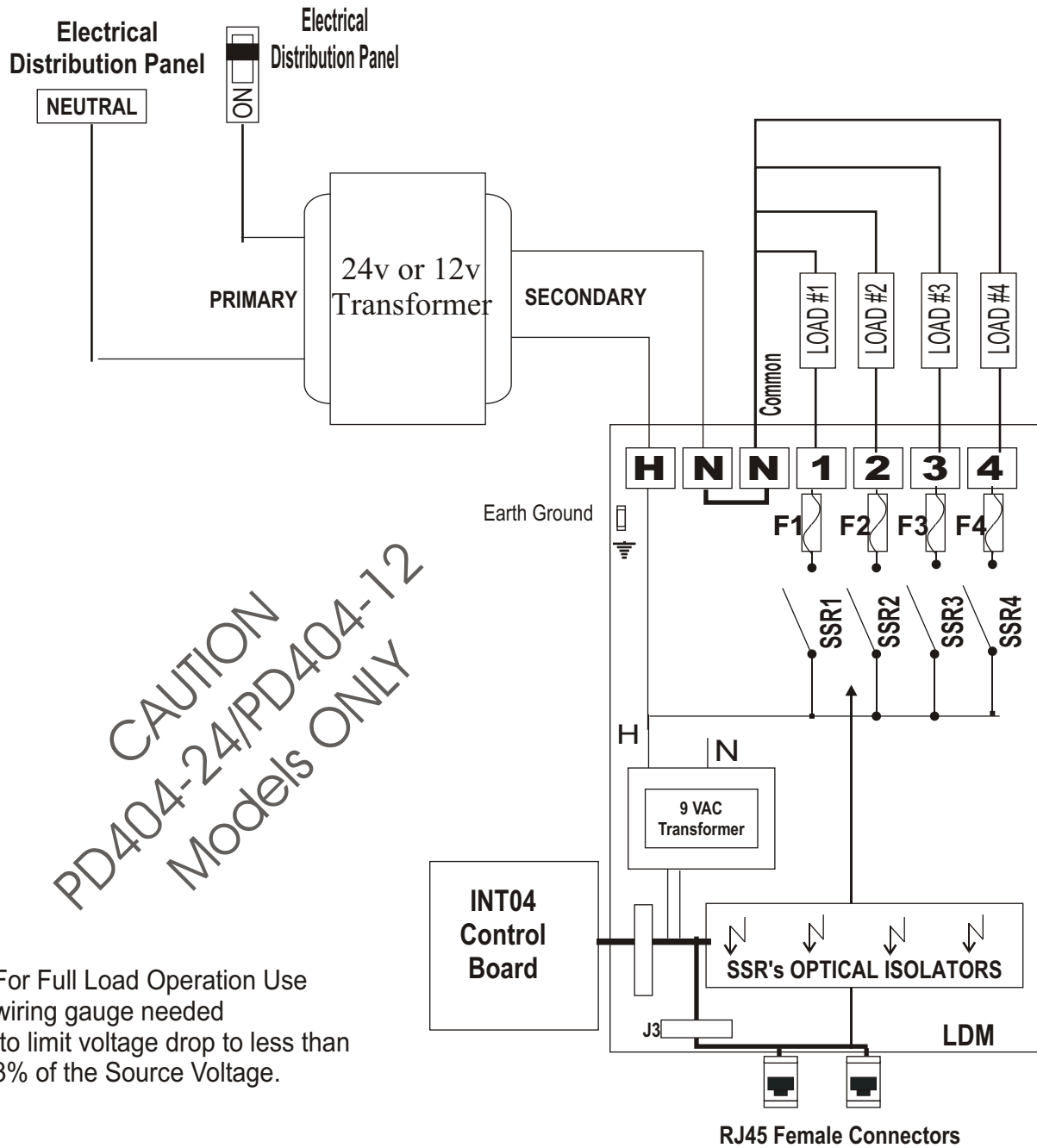

Figure 9 - PD404-24VAC/PD404-12VAC
 Low Voltage Load and Power Wiring



For Full Load Operation Use wiring gauge needed to limit voltage drop to less than 3% of the Source Voltage.

NOTES

- 1 With PD404-24 you may use a single 24 VAC-400 VA or better transformer.
- 2 With PD404-12 you may use a single 12 VAC-200 VA or better transformer.
- 3 Follow transformer's installation & wiring instructions from manufacturer.
- 4 Maximum Load Per Output: 50 Watts at 12 VAC.
- 5 Maximum Load Per Output: 100 watts at 24 VAC.

PROTOCOL Address Setting

Up to 63 uniquely addressed INT04 boards (two in each **PD804**, one in each **Pd404**, **PD408** and **PD216**) may be installed in any one system. Each **INT04** must be set to a unique decimal address between 1 and 63. **INT04** #63 output 4 is not available for use. Total number of zones ((63 x 4) - 1 = 251). Refer to **TABLE 4** On **Page 9** of this manual for proper setting of the address selectors S1 and S2 on the **PD404**.

Example:

S2 & S1 should be set respectively to **1 & A** if the desired address is 26 (1 x 16 + A = 26, A=10). In this example, outputs 1 through 4 of **PD404** # 26 are referred to as 26.1, 26.2, 26.3 and 26.4 when configuring buttons on PROTOCOL stations, using the PROTOCOL **"SOFTPRO"** programming software. Address used must not be an address already used elsewhere in the system).

NOTE:

It is also possible to quadruple the maximum number of outputs on a system up to 1004 circuits. An **INT04** may have a decimal address of up to, and including, 252. Please contact factory for more details. For a complete Decimal to Hexadecimal conversion chart, please refer to **Appendix A** in the PROTOCOL **Hardware** and **Software Manuals**.

Non-Dim Output Setting

Whilst outputs may be programmed to dim or not dim through the "SOFTPRO" configuration software, in some circumstances it may be preferable for all four outputs in the **PD404** to be configured for non-dim (switch only) operation by a **hardware lock**. This prevents inadvertent dimming, or damage, of loads that cannot be dimmed, such as contactors, mechanical relays, motors, non-dim fluorescent, etc...

Since this procedure involves adding a jumper to the **INT04** board, it is preferable to have it performed by the factory, at time of order. However, any qualified electronic technician can perform the procedure in the field when necessary. **Figure 10** shows the location for installing the non-dim (ND) jumper.

Jumper to Ensure Non-Dim function of INT04 to be installed here.

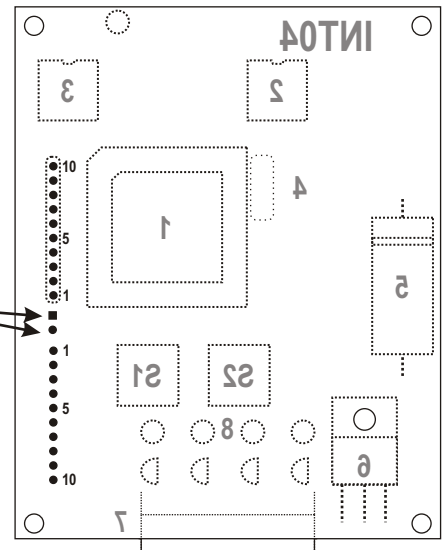

INT04 Solder (Back) Side

Figure 10 - PD404 INT04 DETAIL

PD404 Installation Check List

BEFORE ENERGIZING THE PD404 MAKE SURE:

- Loads are tested before connecting to dimmers.
- PD404** has been properly grounded.
- All line voltage screw terminals are properly tightened to prevent hot spots.
- Low voltage data lines connections are properly insulated.
- Low voltage data lines polarity is observed throughout the system.
- The **PD404**'s INT04 is set to the right addresses.

Table 4 - PD DIMMER Address Selection Information

00	INVALID ADDRESS	33	set S2,S1 to 2,1
01	set S2,S1 to 0,1	34	set S2,S1 to 2,2
02	set S2,S1 to 0,2	35	set S2,S1 to 2,3
03	set S2,S1 to 0,3	36	set S2,S1 to 2,4
04	set S2,S1 to 0,4	37	set S2,S1 to 2,5
05	set S2,S1 to 0,5	38	set S2,S1 to 2,6
06	set S2,S1 to 0,6	39	set S2,S1 to 2,7
07	set S2,S1 to 0,7	40	set S2,S1 to 2,8
08	set S2,S1 to 0,8	41	set S2,S1 to 2,9
09	set S2,S1 to 0,9	42	set S2,S1 to 2,A
10	set S2,S1 to 0,A	43	set S2,S1 to 2,B
11	set S2,S1 to 0,B	44	set S2,S1 to 2,C
12	set S2,S1 to 0,C	45	set S2,S1 to 2,D
13	set S2,S1 to 0,D	46	set S2,S1 to 2,E
14	set S2,S1 to 0,E	47	set S2,S1 to 2,F
15	set S2,S1 to 0,F	48	set S2,S1 to 3,0
16	set S2,S1 to 1,0	49	set S2,S1 to 3,1
17	set S2,S1 to 1,1	50	set S2,S1 to 3,2
18	set S2,S1 to 1,2	51	set S2,S1 to 3,3
19	set S2,S1 to 1,3	52	set S2,S1 to 3,4
20	set S2,S1 to 1,4	53	set S2,S1 to 3,5
21	set S2,S1 to 1,5	54	set S2,S1 to 3,6
22	set S2,S1 to 1,6	55	set S2,S1 to 3,7
23	set S2,S1 to 1,7	56	set S2,S1 to 3,8
24	set S2,S1 to 1,8	57	set S2,S1 to 3,9
25	set S2,S1 to 1,9	58	set S2,S1 to 3,A
26	set S2,S1 to 1,A	59	set S2,S1 to 3,B
27	set S2,S1 to 1,B	60	set S2,S1 to 3,C
28	set S2,S1 to 1,C	61	set S2,S1 to 3,D
29	set S2,S1 to 1,D	62	set S2,S1 to 3,E
30	set S2,S1 to 1,E	63	set S2,S1 to 3,F
31	set S2,S1 to 1,F		
32	set S2,S1 to 2,0		

NOTES:

00 Decimal (S2,S1 = 0,0) is not allowed on any device.

Max **PD404** Address: 63 Decimal (S2,S1 = 3,F)



LIMITED WARRANTY

Digital Lighting Systems, warrants to the purchaser that its products have been carefully manufactured and inspected and are warranted to be free from defects of workmanship and materials when used as intended. Any abuse or misuse contrary to normal operation shall void this warranty.

Digital Lighting Systems' obligation under this warranty shall be limited to replacement or repair of any units as shall within two years of date of invoice from **Digital Lighting Systems**, prove defective; and **Digital Lighting Systems** shall not be liable for any other damages, whether direct or consequential. **The implied warranties of merchantability and fitness for a particular purpose are limited to the duration of the expressed warranty.** Some states do not allow the exclusion of the limitation of incidental or consequential damages, so the above limitation or exclusion may not apply to you. This warranty gives you specific legal rights, you may also have other legal rights which vary from state to state.

Defective merchandise may be returned to **Digital Lighting Systems**, prepaid, after prior notification has been given and approval obtained for the return. To obtain prior approval for the return of the defective items, contact your local Digital Lighting Systems distributor, representative, or:

Digital Lighting Systems, Inc.

12302 SW 128 Ct. Bay#105

Miami, FL 33186

(305) 969-8442

Upon request, replacement unit(s) will be shipped as soon as available. Unless immediate shipment of replacement merchandise is requested, **Digital Lighting Systems** will not ship replacement merchandise until defective merchandise is received, inspected, and determined to be defective.

No labor charges in connection with warranty problems will be reimbursed by Digital Lighting Systems without prior written approval from the factory.

Digital Lighting Systems distributors and representatives have no authority to change this warranty without written permission.

Digital Lighting Systems reserves the right to determine the best method of correcting warranty problems.





Digital Lighting Systems, Inc.
12302 SW 128 Ct. Bay#105
Miami, FL 33186
www.digitallighting.com

Tel 305-969-8442
Fax 305-969-8675
e-m info@digitallighting.com

Printed in U.S.A.
February 2003