

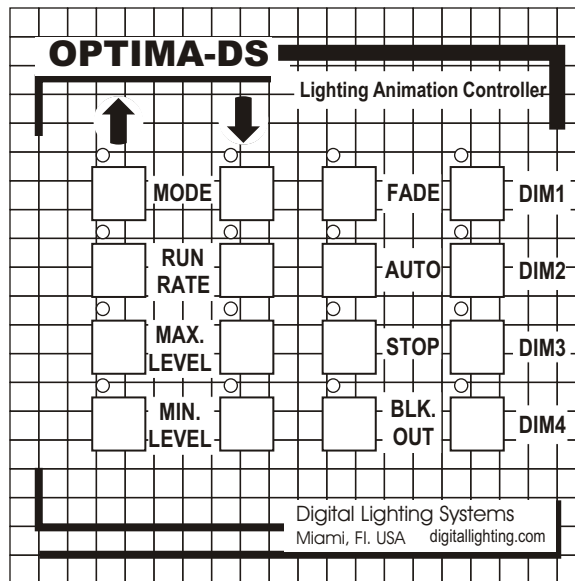

Digital Lighting Systems, Inc.

OPTIMA-DS Series DMX CHASER/CROSS-FADER Controllers



MODEL NUMBERS

- OPTIMA-DS
- OPTIMA-DS2
- OPTIMA-DS2C

USER MANUAL

Single-Gang Models

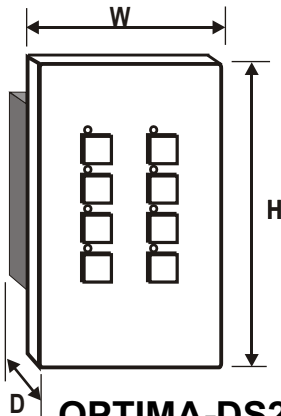

OPTIMA-DS2
OPTIMA-DS2-C

Double-Gang Models

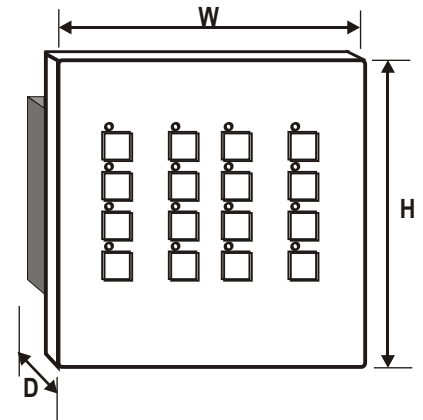

OPTIMA-DS

Maximum Outside Dimensions

MODEL	WIDTH	HEIGHT	DEPTH	GANG
OPTIMA-DS2	2.700"	4.600"	1.650"	Single
OPTIMA-DS2-C	067 mm	117 mm	042 mm	
OPTIMA-DS	4.600"	4.600"	1.650"	Double
	117 mm	117 mm	042 mm	

DEPTH (D) includes circuit board with components

INTRODUCTION

The **OPTIMA DS** is a four-channel 16-pattern lighting cross-fader with master and individual channel dimming. Controls for adjusting the off-level and fade rate are also standard on the unit. This new design employs the latest electronic technology and presents a control panel with a sleek modern look and simple to use controls. Added features include a standard **DMX-512** output. When in dynamic mode, the **OPTIMA-DS** creates dazzling light shows from its built-in repertoire of lighting animation sequences. In static mode, the **OPTIMA-DS** acts as a four-circuit dimmer with a black-out control. The **OPTIMA DS** can also work in a traditional chase mode. In short, whether your lighting project requires sharp light sequencing or a more subtle cross-fade mixing of colors, the **OPTIMA-DS** provides you with a perfect solution. The **DMX-512** compatibility makes the **OPTIMA-DS** a perfect and inexpensive solution for retrofit applications by working with existing **DMX-512** dimmers. The **OPTIMA-DS2** models do not have individual channel dimmers and mount in a single-gang masonry box. The **OPTIMA DS** requires a double-gang masonry box.

OPTIMA-DS FEATURES

- ◆ Economical.
- ◆ 4-Color / 4-Channel Sequencing.
- ◆ 16 Exciting Light / Color Patterns.
- ◆ Cross-Fade and Chase Modes.
- ◆ Static 4-Ch. Dimmer Mode with Master.
- ◆ Automatic Pattern Change Mode.
- ◆ Single Pattern Select Mode.
- ◆ Independently Adjustable Chase Rate.
- ◆ Independently Adjustable Fade Rate.
- ◆ Blackout Switch.
- ◆ Master Off-Level Adjustment.
- ◆ Settings are saved in Nonvolatile Memory.
- ◆ Simple Pushbutton Operation.
- ◆ LED Mode Indicators.
- ◆ Custom Patterns Available.
- ◆ Available in **3, 4, 5, 6, 7 & 8 Channels.**

APPLICATIONS

- Architectural & Decorative Lighting.
- Landscape Lighting.
- Structure Lighting.
- Pond and Fountain Lighting.
- Museums and Art Galleries.
- Movie Theaters.
- Theme Parks.
- Fair Rides.
- Point of Sale Displays.
- Christmas Trees and Displays.
- Electric Sign Animation.
- Entertainment and Club Lighting.

Physical and Electrical Specifications

Back Plate:	Metal Construction.
Dimensions:	See Table Above.
Power:	Max. 80 mA at 10 VAC-50/60 Hz.
Data Output:	RS485 Compliant.
Output Drive:	256 1/8 DMX Loads.
Data Format:	Standard DMX-512 Protocol.
Data Retention:	10 years, no batteries required.
ESD Protection:	15 KV on data input and output.
DS Port:	Standard 5-pin XLR Female.
DS2 Port:	0.1" c-c, 8 Position Male Header. Available with pigtail DMX-512 Adapter.

OPTIMA DS2 & DS2-C

Same features as DS except no individual channel dimming. They mount in a single-gang masonry box. DS2-C is a chase only version with no fade option.

PD408-DMX DIMMER PACK

The OPTIMA DS requires an external dimmer pack with a DMX cable. Any DMX-512 compatible dimmer may be used. Digital Lighting Systems, Inc. manufactures high quality low cost DMX-512 dimmer packs. The **PD408-DMX** is an excellent companion to the OPTIMA DS. It can drive four 960 Watt 120 VAC loads at 50 and 60Hz. 12/24/220 VAC versions are available.

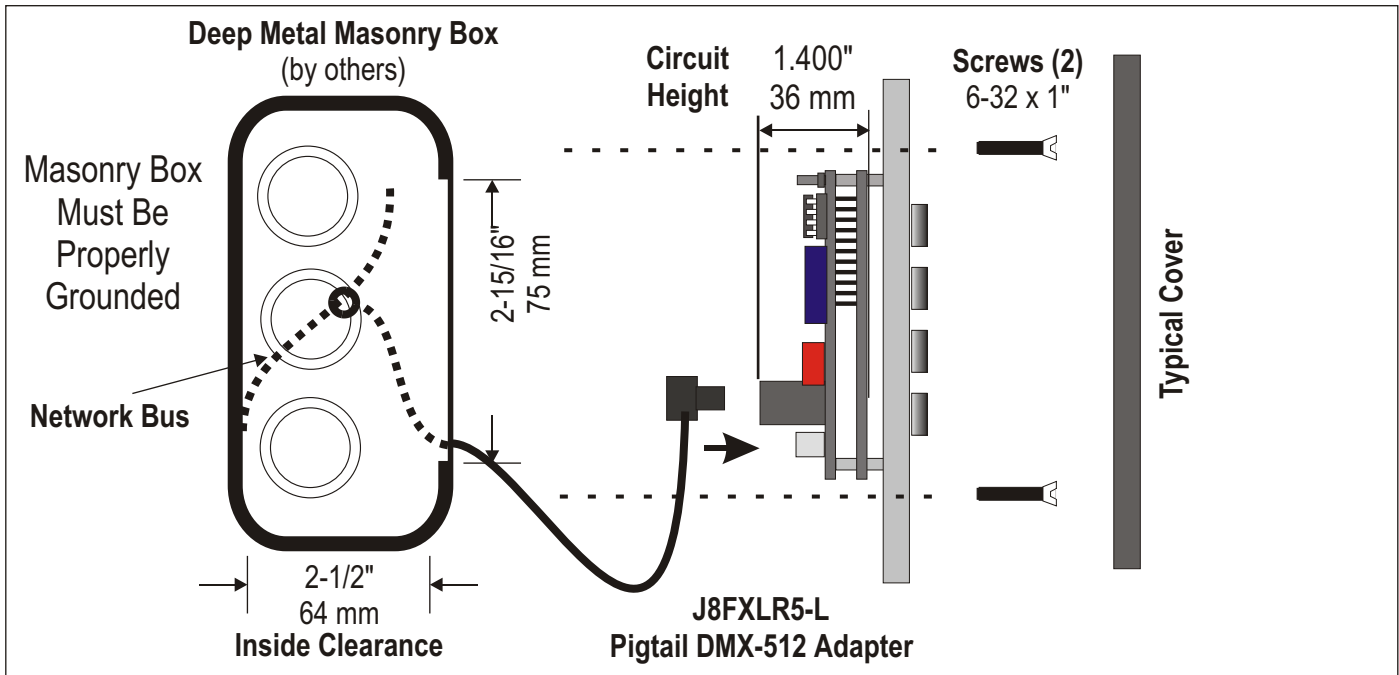

Mounting requirements

- The OPTIMA DS mounts in double-gang deep masonry box or may be ordered in a table top aluminum enclosure. The Female XLR connector comes mounted on the side of the enclosure. The OPTIMA DS2 is only available for mounting in a single-gang masonry box.
- Both types of masonry boxes must have a minimum depth of 2-1/2" and a minimum inside height of 2-15/16" to allow clearance for printed circuit board. (See above illustration.)
- Use Grounded metal boxes only.

Ordering Information

- OPTIMA-DS:** Cross-Fader/Chaser/4-Channel Dimming Controller, 2-G size.
- OPTIMA-AE:** Alum.Enclosure for OPTIMA DS.
- OPTIMA-DS2:** Cross-Fader/Chaser 1-G size.
- OPTIMA-DS2C:** Chaser 1-G size.
- J8FXLR5-L:** Pigtail DMX-512 XLR Adapter. L= (Length in feet).

Wiring Notes

- All wiring between the OPTIMA and dimmer packs is low voltage (NEMA Class 2) and must be a shielded twisted pair cable. Refer to the OPTIMA User's Manual for more details.
- Standard industry DMX-512 cables may be used with the OPTIMA.
- Do not run DMX cable in the same conduit with non-class 2 circuits.
- The OPTIMA is supplied with an external low voltage wall adapter.
- Power for the adapter may be on a different power phase from power supplying the DMX-512 dimmer packs or fixtures.
- Installation must conform to local and/or NEC code requirements.

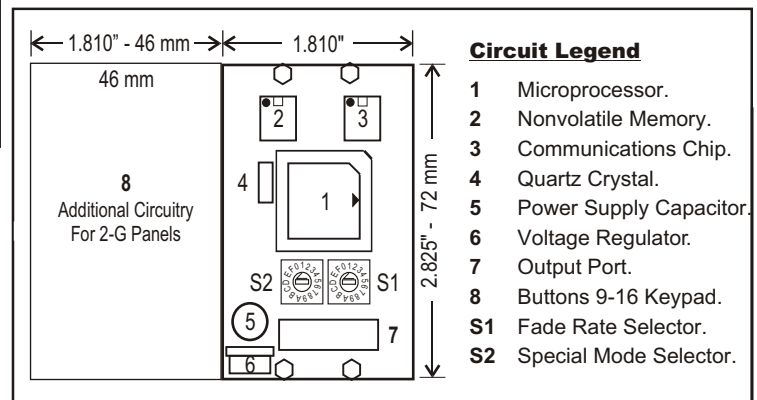

A General Information

The OPTIMA Series controllers use low-power electronic components and do not directly connect to high voltage supply or electric loads. They are powered by an external low-voltage transformer. The loads connect to a separate DMX-512 compatible dimmer pack(s). The OPTIMA controls the outputs of the dimmer pack(s) by sending a series of digital dimming levels over a low voltage cable. Several DMX dimmer packs may be connected to the same control cable in a daisy-chain configuration. The DMX information is received by all dimmers and each pack extracts and uses the portion of the information that is intended for it. This is accomplished by setting each dimmer pack to a different DMX address by way of address selectors. It is possible to have several dimmer packs set to the same address when controlling loads that exceeds the dimmer's output capacity. Loads may be broken into smaller sections and still be controlled as a single load by any particular DMX

B Number of Channels Configuration

The OPTIMA Series controllers may control 3 to 8 channels of DMX. They must be configured to the correct number of channels as required by the application. There are two hexadecimal selectors on the back of the unit. The selector marked S1 is used to select the number of channels controlled. Figure 1 illustrates how to select the desired number of channels.

C OPTIMA DMX Output

The information sent by the OPTIMA is in accordance with the DMX-512 standard control protocol. When set to 3 or 4 channels, the OPTIMA sends control information over the first 4 DMX addresses. When set to between 5 and 8 channels, it uses the first 8 DMX addresses. All remaining addresses, up to 512, are sent a DMX off-level. Figure 2 below shows the various DMX outputs generated by the OPTIMA according to the number of channels setting.

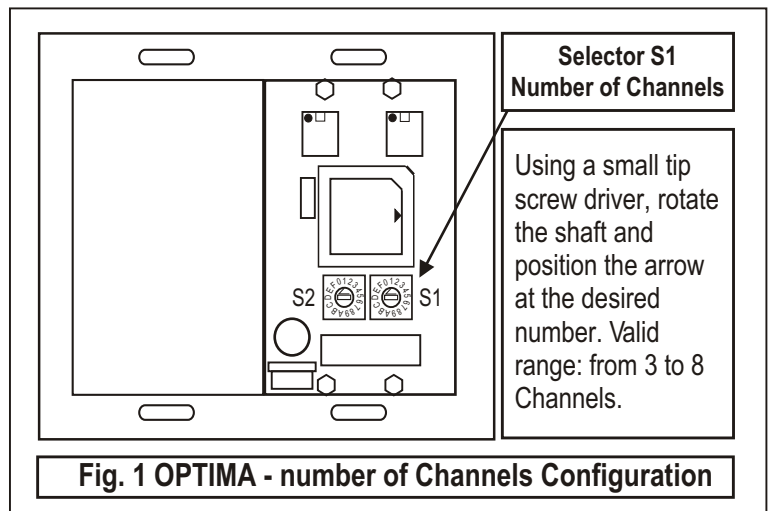

Fig. 1 OPTIMA - number of Channels Configuration

DMX OUTPUT	Channel 1	Channel 2	Channel 3	Channel 4	Channel 5	Channel 6	Channel 7	Channel 8	Channel 9	••••	Channel 512
3 Ch. Values	Level 1	Level 2	Level 3	X	0	0	0	0	0	••••	0
4 Ch. Values	Level 1	Level 2	Level 3	Level 4	0	0	0	0	0	••••	0
5 Ch. Values	Level 1	Level 2	Level 3	Level 4	Level 5	X	X	X	0	••••	0
6 Ch. Values	Level 1	Level 2	Level 3	Level 4	Level 5	Level 6	X	X	0	••••	0
7 Ch. Values	Level 1	Level 2	Level 3	Level 4	Level 5	Level 6	Level 7	X	0	••••	0
8 Ch. Values	Level 1	Level 2	Level 3	Level 4	Level 5	Level 6	Level 7	Level 8	0	••••	0

Key: Level = Value sent depending on pattern X = Unpredictable Value 0 = Off Level

FIG. 2 - OPTIMA DMX OUTPUT FORMAT ACCORDING TO NUMBER OF CHANNELS SETTING

D - Installation Instructions (See Figs. 4 & 5 below).

1. Install the OPTIMA in a convenient location. Fig. 4 shows an OPTIMA-DS which has a female XLR connector mounted on the side of its aluminium enclosure. OPTIMA-DS2 models are mounted in deep single gang masonry boxes and have a female XLR connector mounted externally (See Fig. 5 below).
2. Provide a standard power outlet with a toggle switch for the wall transformer. Plug the supplied transformer to the OPTIMA using the Molex connector plugs. The OPTIMA may remain energized at all times. The loads can be turned off by using the front panel 'Black-Out' button.
3. Install the DMX dimmer pack and follow the wiring instructions in its user manual.
4. Connect the OPTIMA to the Dimmer Pack using the DMX cable (DMX-CC-LEN) to either internally or externally mounted XLR connector. Skip to Operating Instructions.

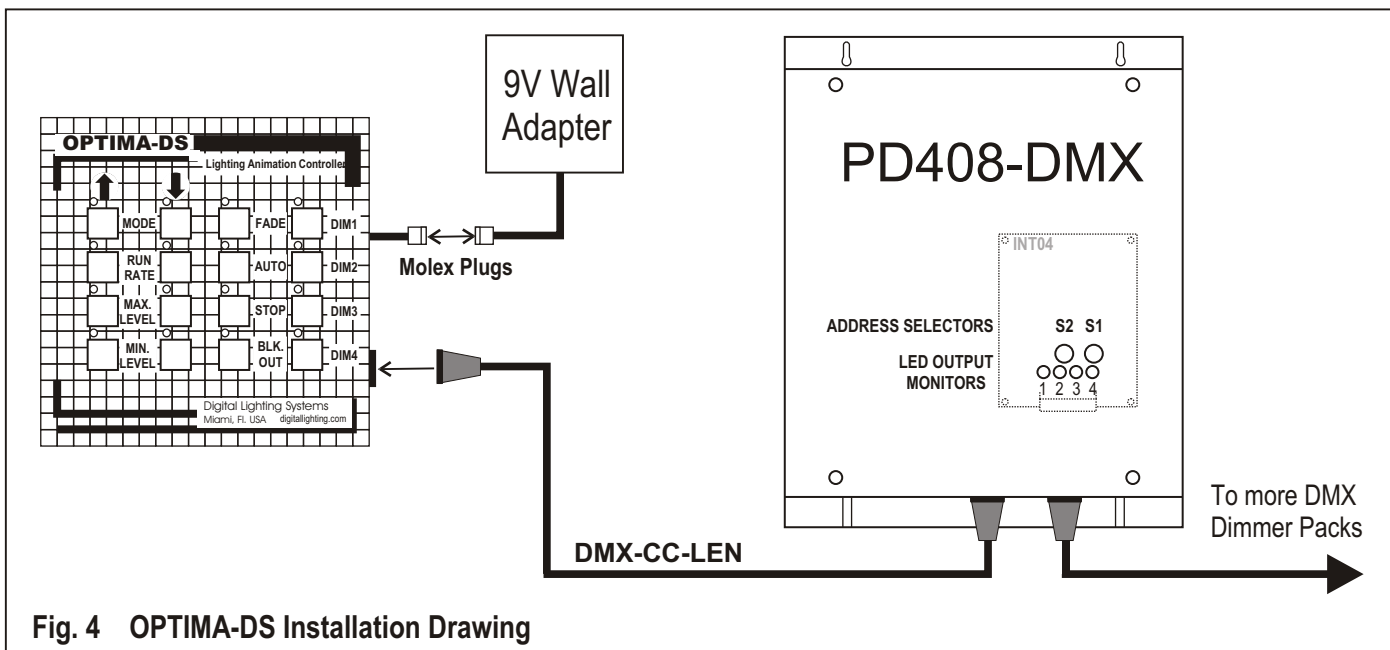

Fig. 4 OPTIMA-DS Installation Drawing

E - OPTIMA DMX and Power Connections

The OPTIMA panels use a standard 5-Pin Female XLR connector to connect to DMX equipment as seen in Figs. 4 & 5. They are also available on request with an unterminated pigtail that plugs into the back of the unit so that customer may make their own DMX connections or with a pre-terminated cable with XLR connector to the customer's desired length (J8FXLR5-L). An external transformer supplies power via a 2-pos. Molex type connector.

Power and DMX pin assignments are shown in Fig. 6.

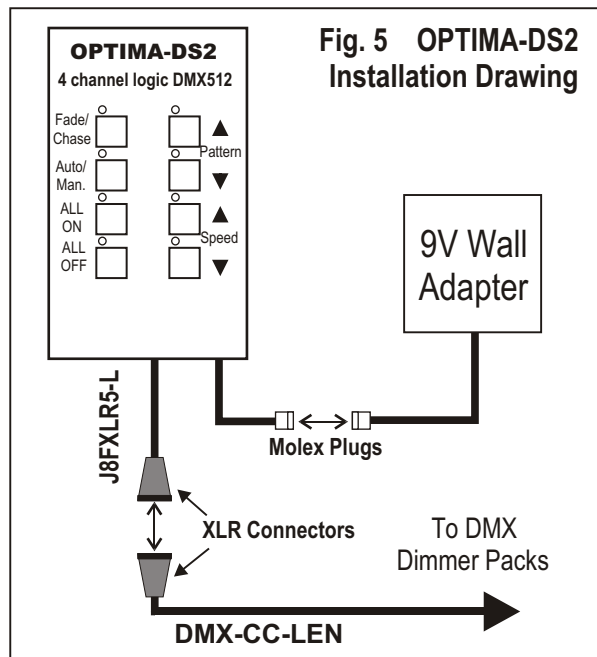
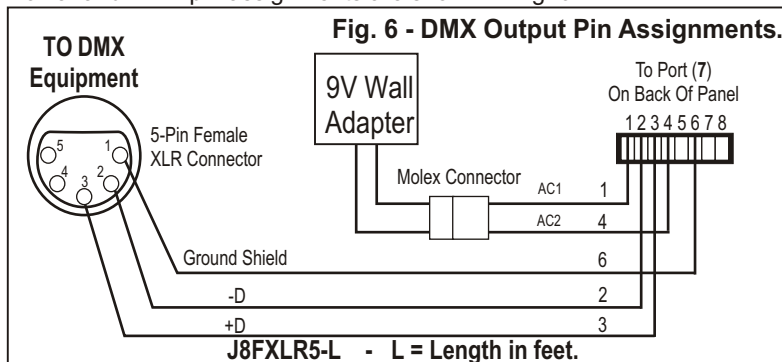

Fig. 5 OPTIMA-DS2 Installation Drawing

OPTIMA-DS Operating Instructions

I. Introduction

The OPTIMA-DS is a 16-pattern, DMX-512 chaser/cross-fader logic controller. The number of channels can be set to any value from 3 to 8 using a rotary selector on the back of the unit. Maximum and minimum level adjustment masters are provided with individual control for the first 4 channels. When operating as a chaser, The OPTIMA-DS switches its outputs between maximum and minimum levels. When cross-fading, the outputs gradually ramp from one level to the next.

The OPTIMA-DS has simple to use push-button controls with LED indicators. Following is a description of the buttons and the various functions they perform.

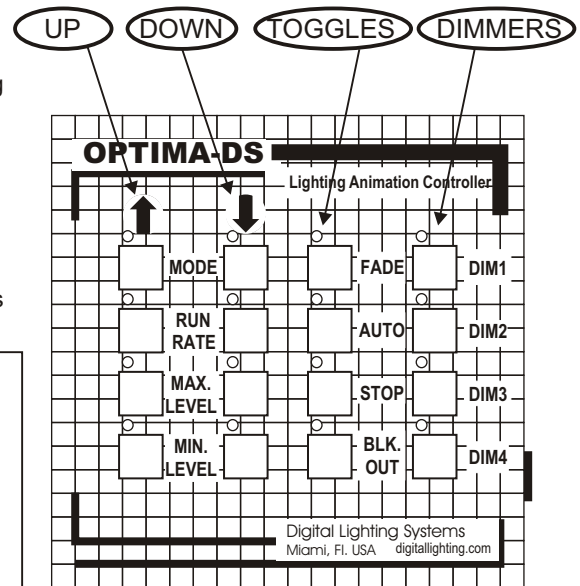

Fig. 7 The OPTIMA DS Front Panel

II. The Control Panel

A- Dual Button Controls

The following four pairs of up/down control buttons are used to select the chase (or fade) pattern, the chase (or fade) rate and to set the minimum and maximum master levels. Momentarily pressing and releasing a button causes the associated value to increment (decrement) in single steps. Pressing and holding a button causes a more rapid variation that stops when the button is released.

1- MODE (Up-Down Buttons)

The "MODE" up-button increments the pattern number from 1 to 16. Its associated LED turns on when pattern number 16 is reached. The "MODE" down-button performs the reverse operation and its associated LED turns on when pattern number 1 is reached.

3- MAX. LEVEL (Up-Down Buttons)

The "MAX. LEVEL" up-button is used to gradually increase the maximum master level up to 100%. Its associated LED turns on when 100% is reached. The "MAX. LEVEL" down-button performs the reverse operation and its associated LED turns on when 0% is reached.

2- RUN RATE (Up-Down Buttons)

The "RUN RATE" up-button increments the chase speed from 1 to 255. Its associated LED turns on when the speed reaches a maximum of 255. The "RUN RATE" down-button performs the reverse operation and its associated LED turns on when the speed reaches a minimum of 1.

4- MIN. LEVEL (Up-Down Buttons)

The "MIN. LEVEL" up-button is used to gradually increase the minimum master level up to 100%. Its associated LED turns on when 100% is reached. The "MIN. LEVEL" down-button performs the reverse operation and its associated LED turns on when 0% is reached. The minimum level is used to prevent the outputs from completely turning off. This feature creates a very attractive special effect to lighting displays.

B- Single Button Toggle Controls

The following four buttons work as toggles. They turn the function on, if previously off, and turn it off, if previously on.

1 - FADE SELECT

If the fade mode had been previously selected, depressing the Fade Select button switches the OPTIMA DS to the chase mode and vice-versa. The associated LED turns on when the selected mode is fade.

2 - AUTO SELECT

Selecting the AUTO mode causes the OPTIMA-DS to automatically scroll through all 16 chase patterns. Otherwise, the same pattern repeats unless changed using the MODE up/down buttons. The associated LED is on when Auto is selected.

3 - STOP SELECT

Selecting the STOP mode stops the chasing and fading cycles and causes all channels to go into a static mode. The OPTIMA-DS effectively becomes a simple DMX console with 4 individually dimmable channels, using DIM1 to DIM4 buttons, and a MAX. LEVEL master. The LED associated with the STOP button turns on to indicate that the OPTIMA-DS is operating in a static dimmer mode.

4 - BLKOUT SELECT

When selected, the associated LED turns on. All channels are blacked out and go to 0% intensity.

C- DIMMER buttons

DIM1-DIM4

The individual levels of the outputs can be adjusted to any level between 0% and 100%, using the DIM buttons in conjunction with the maximum master control. Each DIM button performs Raise and Lower functions alternately. Pushing and holding a button causes the level of the corresponding output to vary in one direction. Releasing the button and pressing again causes the output level to vary in the reverse direction. The LED's above the DIM buttons indicate the output status of the first four channels.

OPTIMA-DS2/DS2-C Operating Instructions

III. Introduction

The OPTIMA-DS2 and DS2-C are simplified versions of the OPTIMA-DS controller. They have the same features as the DS with the exception on the master and individual dimming controls.

The DS2-C is the same as the Ds2 but is locked on "chase only" by setting selector S2 to 0. The FADE button on the DS2-C is deactivated and does not perform any

IV. Number of Channels Configuration

The number of channels on both models can be set to any value between 3 to 8 using rotary selector S1 on the back of the unit. Refer to Fig. 8 to the right.

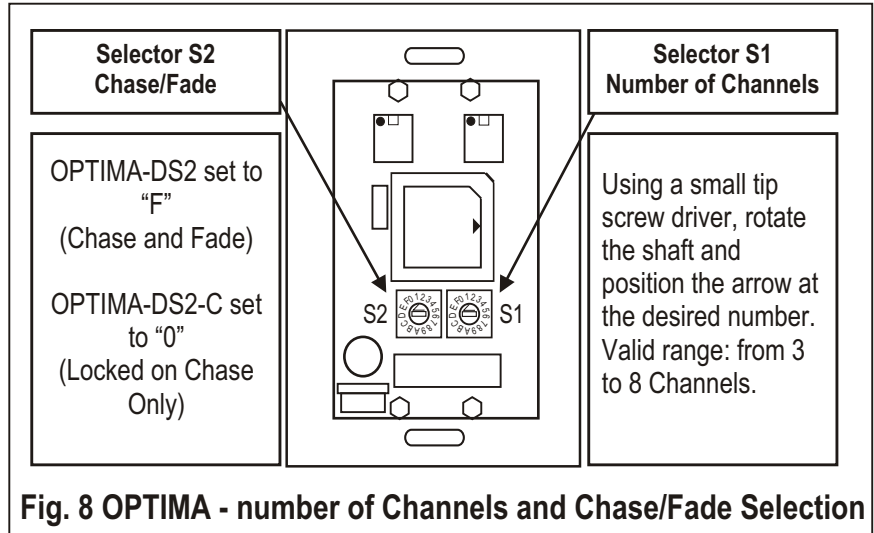

Fig. 8 OPTIMA - number of Channels and Chase/Fade Selection

V. The Control Panel - See figure 9 below.

A- Dual Button Controls

1- PATTERN (Up-Down Buttons)

The "PATTERN" up-button increments the pattern number from 1 to 16. The "PATTERN" down-button performs the reverse operation until number 1 is reached.

2- SPEED (Up-Down Buttons)

The "SPEED" up-button increments the chase speed from 1 to 255. The "SPEED" down-button performs the reverse operation until it reaches a minimum of 1.

The LED'S above these buttons indicate the output status of the first four channels.

B- Single Button Toggle Controls

The following four buttons work as toggles. They turn the function on, if previously off, and turn it off, if previously on.

1 - FADE/CHASE SELECT

If the fade mode had been previously selected, depressing the Fade Select button switches the OPTIMA-DS2 to the chase mode and vice-versa. The associated LED turns on when the selected mode is fade. (Feature disabled on DS2-C version.)

2 - AUTO/MAN. SELECT

Selecting the AUTO/MAN. mode causes the OPTIMA-DS2 to automatically scroll through all 16 chase patterns. Otherwise, the same pattern repeats unless changed using the PATTERN up/down buttons. The associated LED is on when Auto is selected.

3 - ALL ON SELECT

Selecting the ALL ON mode stops the chasing and fading cycles and causes all channels to go into a static ALL ON mode. The associated LED is on when ALL ON is selected.

4 - ALL OFF Select

All channels are blacked out and go to 0% intensity. When selected, the associated LED turns on.

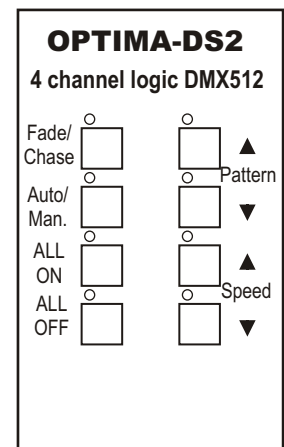

Fig. 9 The OPTIMA-DS2 Front Panel



Patterns for OPTIMA Series Chasers/Cross-Faders

<p>1</p> <p>Light Chase</p>	<p>2</p> <p>Light Chase Back</p>	<p>3</p> <p>Fill & Swipe Forward</p>	<p>4</p> <p>Fill & Swipe Back</p>	<p>5</p> <p>Light Bounce</p>
<p>6</p> <p>Dark Bounce</p>	<p>7</p> <p>Dark Chase</p>	<p>8</p> <p>Dark Chase Back</p>	<p>9</p> <p>Flip-Flop</p>	<p>10</p> <p>Flash All</p>
<p>11</p> <p>Flash Light Chase</p>	<p>12</p> <p>Spring Forward</p>	<p>13</p> <p>Spring Back</p>	<p>14</p> <p>Flash Dark Chase</p>	<p>15</p> <p>Crawl Forward</p>
<p>16</p> <p>Crawl Back</p>				

“All On”/ “All Off” and “Auto Cycle through patterns 1-16” are available by pressing STOP/ BLK OUT and AUTO buttons respectively.



LIMITED WARRANTY

Digital Lighting Systems, warrants to the purchaser that its products have been carefully manufactured and inspected and are warranted to be free from defects of workmanship and materials when used as intended. Any abuse or misuse contrary to normal operation shall void this warranty.

Digital Lighting Systems' obligation under this warranty shall be limited to replacement or repair of any units as shall within one year of date of invoice from **Digital Lighting Systems**, prove defective; and **Digital Lighting Systems** shall not be liable for any other damages, whether direct or consequential. **The implied warranties of merchantability and fitness for a particular purpose are limited to the duration of the expressed warranty.** Some states do not allow the exclusion of the limitation of incidental or consequential damages, so the above limitation or exclusion may not apply to you. This warranty gives you specific legal rights, you may also have other legal rights which vary from state to state.

Defective merchandise may be returned to **Digital Lighting Systems**, prepaid, after prior notification has been given and approval obtained for the return. To obtain prior approval for the return of the defective items, contact your local Digital Lighting Systems distributor, representative, or:

Digital Lighting Systems, Inc.

Attn: Customer Service Department
7588 NW 8th Street
Miami, FL 33126
(305) 264-8391

Upon request, replacement unit(s) will be shipped as soon as available. Unless immediate shipment of replacement merchandise is requested, **Digital Lighting Systems** will not ship replacement merchandise until defective merchandise is received, inspected, and determined to be defective.

No labor charges in connection with warranty problems will be reimbursed by Digital Lighting Systems without prior written approval from the factory.

Digital Lighting Systems distributors and representatives have no authority to change this warranty without written permission.

Digital Lighting Systems reserves the right to determine the best method of correcting warranty problems.





Digital Lighting Systems, Inc.
7588 NW 8th Street
Miami, FL 33126
www.digitallighting.com

Tel 305-264-8391
Fax 305-261-6637
e-m info@digitallighting.com

Printed in U.S.A.
August 2001